

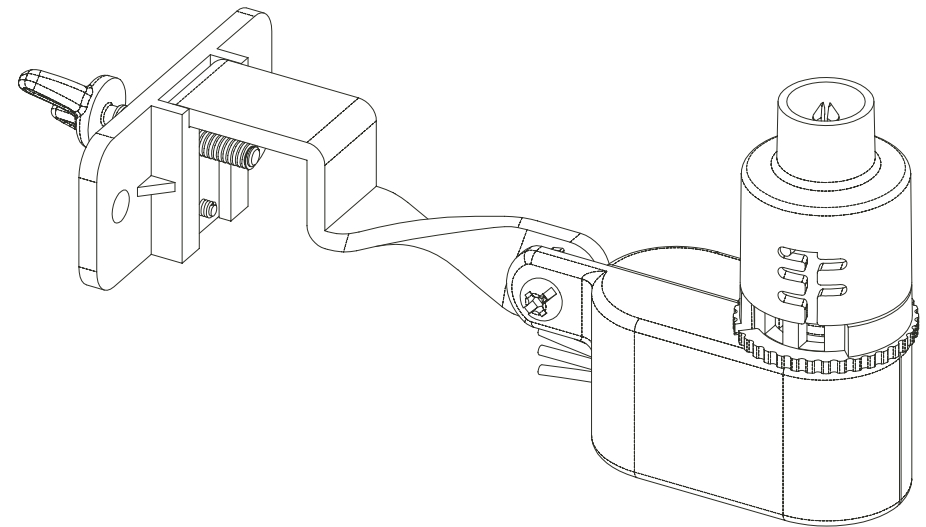

RAIN SENSOR SHUTOFF for Automatic Irrigation Systems



1-800-887-TURF (8873)
www.orbitonline.com



Orbit® Irrigation Products Inc.
North Salt Lake, Utah 84054
57099-24 Rev A



Introduction

In most installations, the Orbit RX-1 acts as a switch to break the circuit to the solenoid on the valves of the irrigation system when it has rained. This allows the timer to advance as programmed, but keeps the valves from opening the water flow, subsequently causing the sprinklers not to come on at the scheduled time. Once the rain sensor has dried sufficiently, the switch closes again to allow normal operation of the sprinkler system.

Three wires extend out of the rain sensor. Two are connected to a 25 ft. extension, and the third center wire is disconnected. The center blue wire is the "normal-open" lead of the switch and is not used in most installations. The remaining two extension wires are colored (one "silver" tinned, the other natural copper); in the following instructions it will not matter which wire is connected at a given junction.

Installation Instructions

Mounting

Mount the rain sensor to a gutter, with the provided thumb screw, or on any surface, with the provided screws, where it will be exposed to direct, unobstructed rainfall (but away from sprinkler spray). The switch-housing portion must be upright (see Figure 1), but the swivel bracket can be moved for mounting on any angled surface.

Hints for mounting:

- Mount as close as possible to the timer. This will cause the wire run to be shorter, which minimizes the possibility of wire breaks.
- Mount in the highest possible position where rain can fall directly upon the rain sensor.
- As described in the "Operation" section of this manual, "reset rate" refers to the amount of time it takes the rain sensor to dry out sufficiently for the sprinkler system to be allowed to come back on. The mounting location will affect this rate and should be taken into consideration should extreme conditions exist. For example, mounting the rain sensor on a very sunny, southeastern end of a building may cause the rain sensor to dry out sooner than desired. Similarly, mounting on the northern end of a building with constant shade may keep the rain sensor from drying soon enough. Some experimentation and use of the "vent ring" (as described later) will usually yield satisfactory results.

Once the rain sensor is mounted, run the wire to the controller, using wire clips every few feet to fasten it. If an extension to the wire provided is needed, use the following table to determine the minimum wire gauge needed:

Extension needed:	25-50 ft.	50-100 ft.	100 ft. or more
then use:	20 AWG	18 AWG	16 AWG

Wiring

Important: The rain sensor is sold and designed for 24-Volt irrigation controllers only. All wiring must conform to applicable local codes.

The two most common wiring situations are detailed below. For non-standard wiring situations, please consult your distributor.

- 24-Volt Solenoid Valves Only (No booster pump) (See Figure 2). With the two wires from the rain sensor at the controller, locate the "common ground" wire of the solenoid valves. If it is connected to the controller disconnect it. Attach one wire of the rain sensor to the "common" terminal (usually marked "COM") on the controller. Attach the other wire of the rain sensor to the common wire leading to the valves. Note: The common wire to the valves does not have to be interrupted at the controller. The Rain sensor may be wired anywhere along the common wire line.
- 24-Volt Solenoid Valves with Booster Pump (See Figure 3). Locate the common wire to the solenoid valves and the common wire lead to the coil of the relay that starts the pump. If these two wires are connected to the "common" terminal on the controller, disconnect both of them.

Twist these two wires together along with one wire from the rain sensor and secure with a wire nut. Attach the other wire of the rain sensor to the "common" terminal on the controller. **Note: The pump circuit output must be 24 volts in this situation if different do not proceed.**

Operation Check to Verify Correct Wiring

Turn on one zone of the sprinkler system that is visible while you are in reach of the rain sensor. Manually depress the spindle at the top of the rain sensor until you hear the switch "click" off. The sprinkler zone should stop instantly. If it does not, check wiring for correct installation.

Adjustments and Operation

The rain sensor can keep the irrigation system from starting or continuing after rainfall quantities of 1/8", 1/4", 1/2", 3/4", or 1". To adjust it to the desired quantity of rainfall, rotate the cap on the switch housing so that the pins are located in the proper slots (See Figure 4). Do not forcibly twist the cap as this might break the pins. The time that it takes the rain sensor to reset for normal sprinkler operation after the rain has stopped is determined by weather conditions (wind, sunlight, humidity, etc.). These conditions will determine how fast the hygroscopic discs dry out, and since the landscape is also experiencing the same conditions, their respective drying rates will roughly parallel each other. There is an adjustment capability on the rain sensor that will slow down the reset rate. By turning the "vent ring" (See Figure 4) to completely or partially cover the ventilation holes, the hygroscopic discs will dry more slowly. This adjustment can compensate for an "overly sunny" installation location or peculiar soil conditions. Experimenting with the vent rings will best determine the ideal vent setting.

Bypassing the Sensor

Should you desire to bypass the operation of the rain sensor for any reason (i.e., turn on your system even though the rain sensor has shut "off" due to rainfall), there is an easy way to do this. Simply go to the rain sensor and raise the rain quantity "cap" setting higher, or completely remove it altogether. This takes the pressure off the switch button, which allows the valve circuit to close again. Note: Using the "manual" switch on the controller will not bypass the sensor.

Maintenance

There is no required maintenance for the unit. The rain sensor does not have to be removed or covered for winterizing purposes. All parts are easily replaceable if they become damaged or lost. The spindle assembly is designed to stay with the cap. Do not pull them apart. (See Figure 4)

Troubleshooting

Follow these simple checks before replacing your rain sensor:

System will not come on at all:

- Check to see that the rain sensor discs are dry and the switch "clicks" on and off freely by pressing the top of the spindle.
- Look for breaks in the wire leading to the rain sensor and check all wire junctions.
- If the rain sensor is dry and the wire leading to it is good, check the rain sensor switch by nicking the insulation of the two "outer" wires near the unit to expose copper. Turn one sprinkler zone on, and apply a "jumper wire" across the two exposed wires. If the sprinkler now comes on, the switch is bad. Wrap all nicked wires with electrical tape.

System will not shut off even after heavy rainfall:

- Check wiring for correct installation. (See "Operation Check to Verify Correct Wiring".)
- Check sensitivity setting on rain sensor, and move the cap to a more sensitive setting. The rain sensor is an accurate rain gauge and can be verified by setting up a "tube" type rain gauge in the same vicinity and making periodic readings.
- Check for obstructions to rainfall such as overhangs, trees or walls.

FIGURE 1: Mounting Rain Sensor

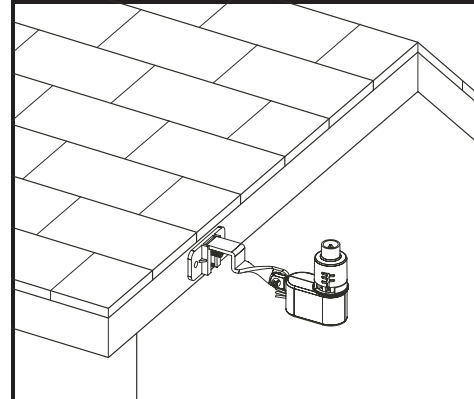

FIGURE 2: Wiring

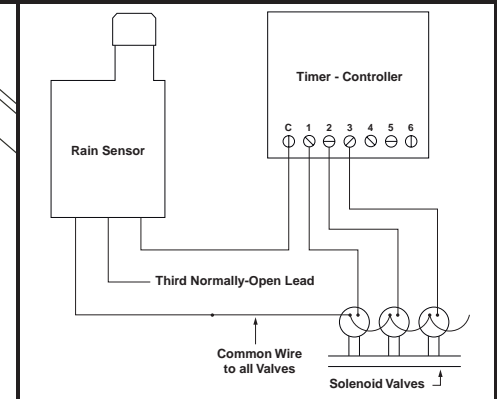

FIGURE 3: Wiring

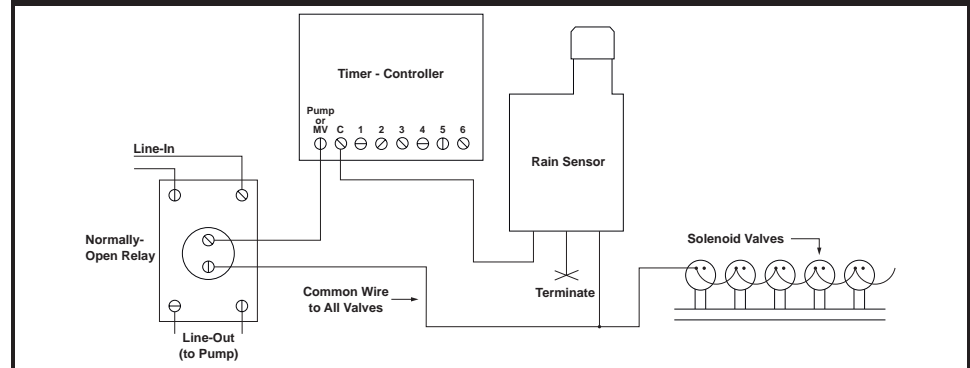
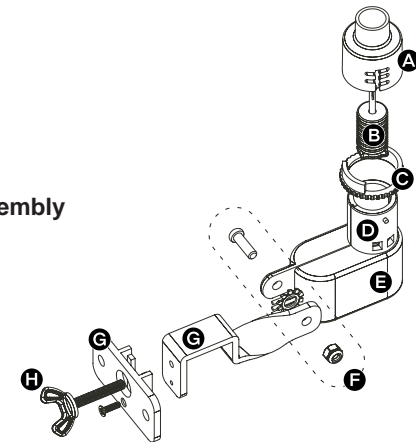

FIGURE 4: Parts Diagram

- A** Cap
- B** Spindle Assembly
- C** Vent Ring
- D** Vent Ports
- E** Housing
- F** Locknut and Screw Assembly
- G** Mounting Bracket
- H** Thumbscrew



Guarantee

Orbit® Irrigation Products, Inc. warrants to its customers that its RX-1 product will be free from defects in materials and workmanship for a period of seven years from the date of purchase. We will replace, free of charge, the defective part or parts found to be defective under normal use and service for a period of up to seven years after purchase (proof of purchase required). We reserve the right to inspect the defective part prior to replacement. Orbit® Irrigation Products, Inc. will not be responsible for consequential or incidental cost or damage caused by the product failure. Orbit® liability under this warranty is limited solely to the replacement or repair of defective parts. To exercise your warranty, return the unit to your dealer with a copy of the sales receipt.